







March 2016

The SI, RRS and NoR are the defining documents.

- Page 1 Sequence Details & Time Limits.
- Page 2 Pre-Race Equipment Check.
- Page 3 Preparation to Race,
 Instructions for Starting Races,
 Instructions for Individual/General Recalls.
- Page 4 Control Box Layout

Warning Time & Sequence Details for Thursday Racing 7th April to 8th September.

1815	1		R19.		R	
1820	2		Laser Handicap.		7	
1825	3		GP 14.		G	
1830	4		Dayboat.		D	
1835	5		Osprey.		O	
1840	6		Joint E, F & 9.		8	

TIME LIMITS FOR RACES:

<u>Time of Year</u>	<u>Time Limit</u>	<u>Extension</u>
Prior to start of British Summer Time	15:30 GMT	20 Minutes
BST started and before 30 Apr	20:00 BST	20 Minutes
1 May to 18 May	20:30 BST	20 Minutes
19 May to 31 July	21:00 BST	30 Minutes
1 Aug to 16 Aug	20:30 BST	20 Minutes
17 Aug to 19 Sept	20:00 BST	20 Minutes
20 Sept until BST ends	18:00 BST	20 Minutes
After BST ends	15:30 GMT	20 Minutes

PRE - RACE EQUIPMENT CHECK

- 1) Switch Mains “ON” (Light Control Box, unless left on due to clock back-up)
- 2) Switch PA amplifier power switch to “ON” (on shelf under Light Control Box)
- 3) Switch on printer (on/off switch at rear and check the cables are plugged in)
- 4) Check horns for finishing, **Finish horn/print time button** for Classes requiring a finish time, e.g. : Handicap (the finish time will be printed out each time it is pressed). **Red Horn Button on Console:** to be used for all other classes.
- 5) Check all lights by switching on required lights:
 - a) Number of CLASS lights needed DOWN to ON
 - b) SHORTEN COURSE light
 - c) PREPARATORY light
 - d) RECALL light

After checking that the lights are **WORKING**, switch off all lights.

- 7) Make sure course numbers boards are available - courses are agreed with the Class captains.
- 8) Make sure there are enough race forms & course instructions (additional supplies in Sailing Office)
- 9) Choose flag of appropriate colour for start line (Cruisers Yellow only):
 - i) YELLOW for E or W or NE 1st leg of the race
 - ii) BLUE for SW 1st leg of the race
 - iii) WHITE for SE or NW 1st leg of the race
 - iv) ORANGE for N or S 1st leg of the race
- 10) Attach “AP” in case of a problem with conditions or starting sequence.

N.B.

Always refer to the Notice of Race and Sailing Programme booklet and any Amendments prior to commencing with the starting sequence. Throughout the season there are a number of Mass Handicap starts and some other minor changes to the normal sequences.

PREPARATION TO RACE

- 1) Put up course numbers - first course in **RED**, next in BLACK and so on.
N.B The course numbers must be posted in CLASS START SEQUENCE starting from the extreme left hand (including the fold-out one) as you face the board for holding the course indicators on the Southern Face of the Race Hut, for group starts list courses left to right **but apply 3) below to FIRST CLASS LIGHT only.**
- 2) Start Lines: Having chosen the line, hoist the appropriate colour flag from the Race Hut (Refer to Club Sailing Instruction 10.3.2)
- 3) Note number of starts required and set that number of Light switches Down to their ON position (i.e. if four starts required set the first four switches Down to ON)
(NOTE for R, E, G, D, O, (9F) 6 STARTS ONLY but 7 courses displayed).
- 4) Press “SET AUTO” switch (set auto light comes on and Class lights go out”.

By now all course numbers should be posted, number of required starts selected and appropriate Start Line Flag flown.

THE STARTING PROCEDURE MUST BE CARRIED OUT AS FOLLOWS

Press “SYNC START” switch normally between 10 and 50 seconds before the first Classes warning signal is required. i.e. (If the first start warning is 18.20 press sync start between 18.19:10 & 18.19:50).

During the start sequence the following are also available within the “FULL AUTO SECTION”:-

- * **INDIVIDUAL RECALL**
If a Class requires an individual recall press and hold for 2 seconds the “INDIVIDUAL RECALL” button to start Class light flashing and sound horn automatically, when boats have returned press again to cancel if however they fail to do so the system will turn off the light after Four minutes.
- * **GENERAL RECALL**
If a General recall is required press and hold for 2 seconds the “GENERAL RECALL”, the system will automatically sound the Classes General Recall and re-position the Classes ‘New Start’ to the end of the sequence correcting the light sequence to take account of the additional start.
- * The system can accept recalls of more than one type and Class.

During the Auto sequence once the countdown has started but before the last gun, reset the light switches to their middle off position (the sequence terminates itself 1 min after the last start inc recalls) finally press Stop Countdown after the last Start.

FOR A PURSUIT RACE YOU WILL NEED TO SELECT A SINGLE START AND MAKE A SOUND SIGNAL EVERY 5 MINUTES UNTILL THE FINAL START

Note!

If you have a problem don't forget the use of the “AP” pennant, turn off the mains to the Control box for 10 seconds to reset the system. After resetting the system, start again as if from scratch (AP down 1 minute before new warning), you can omit the first few classes if they have already started and only select those classes yet to start.

Control Box Layout

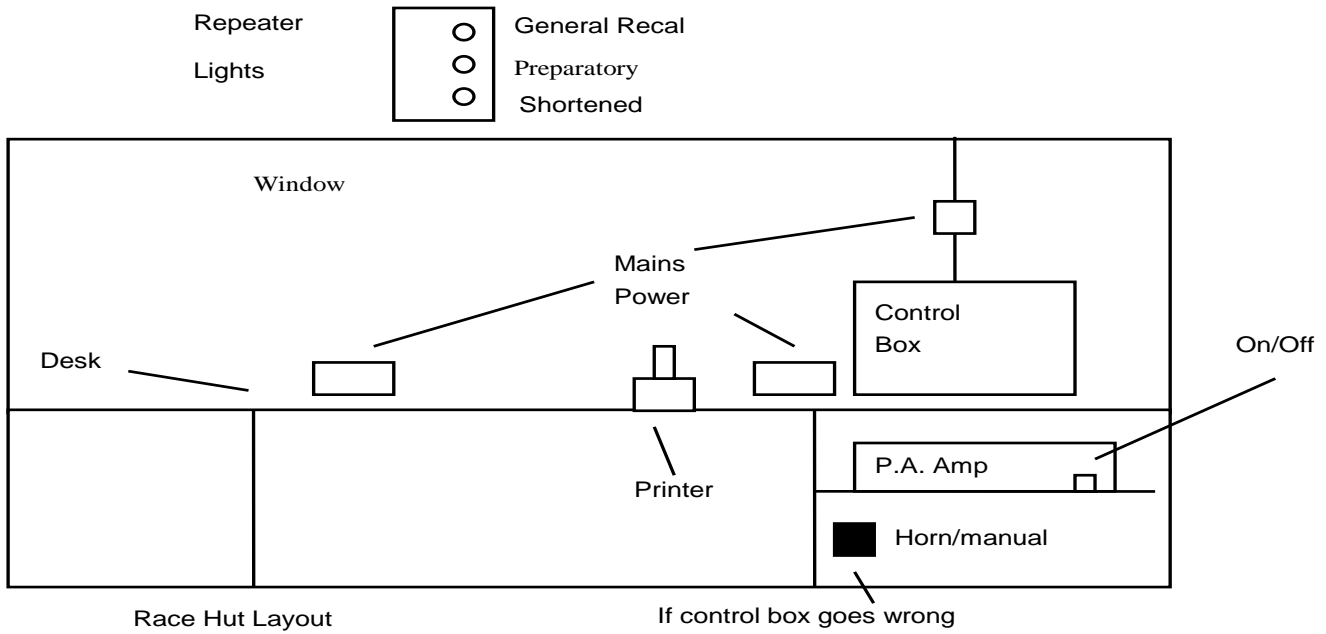

Switch on mains power to :

- i Control Box
- ii P.A. Amplifier
- iii Printer
- iv Radio power supply

Switch on P.A. Amplifier

- Switch on wind indicator
- Switch on Radios (Ch 32, 37 & 14)

